

合金钢

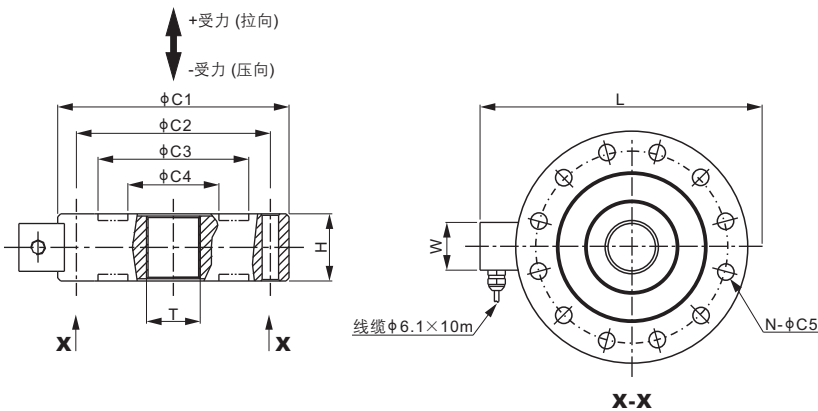
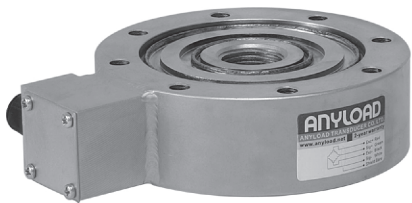

压头需单独订购。

尺寸

量程	C1	C2	C3	C4	C5	L	N	H	W	T
t/mm										
1-5	113.0	97.0	81.0	37.0	7	145.5	8	35.0	32.0	M24X2
10; 20	155.0	130.0	106.0	56.0	11	189.0	12	45.0	32.0	M36X2
30	180.0	150.0	125.0	75.0	13	212.6	12	58.0	32.0	M42X2
50	205.0	165.0	125.0	75.0	13	237.9	16	64.0	32.0	M42X2
100	280.0	228.0	182.0	118.0	17	322.7	16	90.0	48.0	M70X3
150; 200	296.0	256.0	223.0	133.0	22	338.7	16	120.0	48.0	M90X3
300	346.0	282.0	242.0	174.0	26	388.6	16	180.0	48.0	M120X3
lb/inches (由上述尺寸转换)										
2,204.6-11,023.1	4.45	3.82	3.19	1.46	0.28	5.72	8	1.38	1.26	M24X2
22,046.2; 44,092.5	6.10	5.12	4.17	2.20	0.43	7.44	12	1.77	1.26	M36X2
66,138.7	7.09	5.91	4.92	2.95	0.51	8.37	12	2.28	1.26	M42X2
110,231.1	8.07	6.50	4.92	2.95	0.51	9.37	16	2.52	1.26	M42X2
220,462.3	11.02	8.98	7.17	4.65	0.67	12.70	16	3.54	1.89	M70X3
330,693.4; 440,924.5	11.65	10.08	8.78	5.24	0.87	13.33	16	4.72	1.89	M90X3
661,386.8	13.62	11.10	9.53	6.85	1.02	15.30	16	7.09	1.89	M120X3

技术参数			
灵敏度	2.0 mV/V ± 1%	额定激励电压	10V (15V 最大)
零位输出	< ± 0.02 mV/V	绝缘阻抗	> 2 [50V DC] G Ω
非线性	量程 ≤ 5t: < ± 0.050%; 量程 ≥ 10t: < ± 0.30%	正常工作温度范围	-10°C - 50°C / 14°F - 122°F
重复性	量程 ≤ 5t: < ± 0.030%; 量程 ≥ 10t: < ± 0.20%	安全极限载荷	150% 满量程
滞后误差	量程 ≤ 5t: < ± 0.050%; 量程 ≥ 10t: < ± 0.30%	破坏极限载荷	300% 满量程
蠕变	量程 ≤ 5t: < ± 0.050%; 量程 ≥ 10t: < ± 0.10%	密封方式	焊封 / IP67
输入阻抗	770 Ω ± 30	接线方式	Exc+ 红 Exc- 黑
输出阻抗	700 Ω ± 5		Sig+ 绿 Sig- 白
原材料	合金钢		屏蔽线

货号*

量程	货号	毛重(kg)
1t	363YH-1t	2.8
2t	363YH-2t	2.8
3t	363YH-3t	2.8
5t	363YH-5t	2.8
10t	363YH-10t	5.5
20t	363YH-20t	5.5
30t	363YH-30t	12.4
50t	363YH-50t	16.8
100t	363YH-100t	40.6
150t	363YH-150t	51.0
200t	363YH-200t	51.0
300t	363YH-300t	97.2

* ATEX, FM, IECEx 认证版本货号带有 "-Ex" 后缀

与MH363YH承压头配套安装

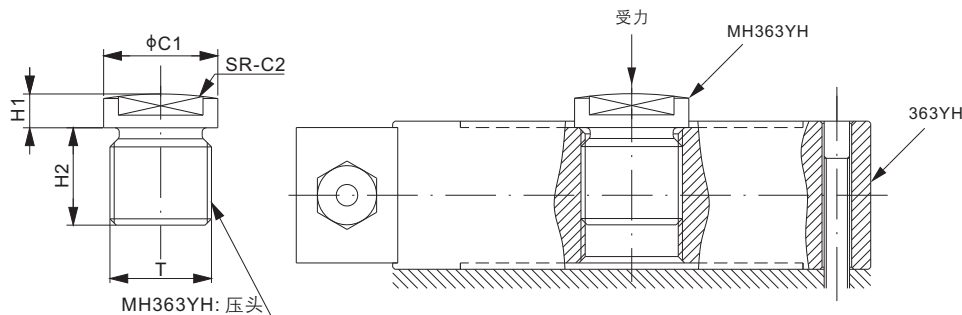

尺寸

货号	传感器量程	C1	C2	H1	H2	T	毛重(kg)
	t/mm						
MH363YH-(1-5)t	1-5	27.0	85.0	8.0	25.0	M24X2	-
MH363YH-(10-20)t	10; 20	45.0	150.0	22.0	38.0	M36X2	-
MH363YH-30t	30	54.0	180.0	32.0	48.0	M42X2	0.97
MH363YH-50t	50	64.0	200.0	42.0	54.0	M42X2	-
MH363YH-100t	100	102.0	300.0	48.0	79.0	M70X3	-
MH363YH-(150-200)t	150; 200	136.0	300.0	60.0	79.0	M90X3	-
MH363YH-300t	300	160.0	500.0	80.0	90.0	M120X3	-
	lb/inches (由上述尺寸转换)						
MH363YH-(1-5)t	2,204.6-11,023.1	1.06	3.35	0.31	0.98	M24X2	-
MH363YH-(10-20)t	22,046.2; 44,092.5	1.77	5.91	0.87	1.50	M36X2	-
MH363YH-30t	66,138.7	2.13	7.09	1.26	1.89	M42X2	0.97
MH363YH-50t	110,231.1	2.52	7.87	1.65	2.13	M42X2	-
MH363YH-100t	220,462.3	4.02	11.81	1.89	3.11	M70X3	-
MH363YH-(150-200)t	330,693.4; 440,924.5	5.35	11.81	2.36	3.11	M90X3	-
MH363YH-300t	661,386.8	6.30	19.69	3.15	3.54	M120X3	-

与REH或EYH+BSP363YH配套安装

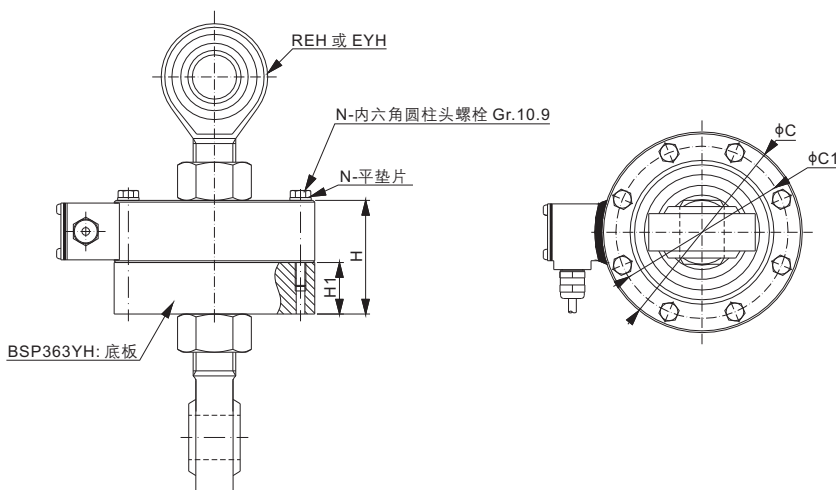

BSP363YH底板套件包含内六角圆柱头螺栓和平垫片

尺寸

货号	传感器量程	C	C1	H	H1	N	匹配螺栓	匹配关节轴承	毛重(kg)
	t/mm								
BSP363YH-(1-5)t	1-5	113.0	97.0	64.0	29.0	8	M6X50	REH-M24	-
BSP363YH-(10-20)t	10; 20	155.0	130.0	90.0	45.0	12	M10X60	EYH-M36	-
	lb/inches (由上述尺寸转换)								
BSP363YH-(1-5)t	2,204.6-11,023.1	4.45	3.82	2.52	1.14	8	M6X50	REH-M24	-
BSP363YH-(10-20)t	22,046.2; 44,092.5	6.10	5.12	3.54	1.77	12	M10X60	EYH-M36	-